

Features

- RoHS lead-free-solder and lead-solder-exempted products are available
- Input voltage up to 144 VDC
- Single output 5 to 48 V
- No input-to-output isolation
- High efficiency up to 95%
- Extremely wide input voltage range
- Low input-to-output differential voltage
- Very good dynamic properties
- Input undervoltage lockout
- Output voltage adjustment and inhibit function
- Continuously no-load and short-circuit proof
- All boards are coated with a protective lacquer
- Board or chassis mountable

Safety-compliant to UL/CSA 60950-1 2nd Ed.



Description

The PSA Series of positive switching regulators are designed as power supplies for electronic systems when no input-to-output isolation is required. Their major advantages include a high level of efficiency, high reliability, low output ripple, and excellent dynamic response. Models with input voltages up to 144 V are especially designed for secondary-switched and battery-driven mobile applications. The

regulators are suitable for railway applications according to EN 50155 and EN 50121.

The case design allows for operation up to 71 °C. The PSA Series is designed for wall or chassis mounting with faston connections or with solder pins for insertion into a PCB.

Various options are available to adapt the regulators to different applications.

Table of Contents

Table of Contents	Page	Page	
Description	1	Electromagnetic Compatibility (EMC)	10
Model Selection	2	Immunity to Environmental Conditions	11
Functional Description	3	Mechanical Data	12
Electrical Input Data	4	Safety and Installation Instructions	12
Electrical Output Data	6	Description of Options	13
Auxiliary Functions	9	Accessories	14

Model Selection

Table 1: PSA Series

Output voltage $V_{o\ nom}$ [V]	Output current $I_{o\ nom}$ [A]	Operating input voltage range V_i [V]	Nom. input voltage $V_{i\ nom}$ [V]	Efficiency ²		Type designation	Options
				η_{min} [%]	η_{typ} [%]		
5	2	8 – 80	40	71.5	74	PSR52-7	Y
5	3	8 – 80	40	77	79	PSR53-9i	-7, P, R, Y, G
5	4	7 – 40	20	82	83	PSR54-9i	-7, P, R, Y, G
5	5	7 – 35	20	81	83	PSA55-9i	-7, P, R, Y, G
5.1	2	8 – 40	20	75	-	PSA5A2-2	iRY ³
5.1	5	7 – 35	20	83	-	PSA5A5-2	iRY ³
12	1.5	18 – 144 ¹	60	86	87	PSA121.5-9i	-7, P, R, Y, G
12	2.5	15 – 80	40	86	87	PSR122.5-9i	-7, P, R, Y, G
12	3	15 – 40	20	89	-	PSA123-2	iRY ³
15	1.5	22 – 144 ¹	60	86	87	PSA151.5-9i	-7, P, R, Y, G
15	2.5	19 – 80	40	88	89	PSR152.5-9i	-7, P, R, Y, G
15	3	19 – 40	30	90	-	PSA153-2	iRY ³
24	1.5	31 – 144 ¹	60	92	93	PSA241.5-9i	-7, P, R, Y, G
24	2	29 – 80	50	91	92	PSR242-9i	-7, P, R, Y, G
24	2.5	29 – 60	40	93	-	PSA242.5-2	iRY ³
36	1.2	44 – 144 ¹	80	94	95	PSA361-9i	-7, P, R, Y, G
36	2	42 – 80	60	92	94	PSR362-9i	-7, P, R, Y, G
48	1	58 – 144 ¹	80	94	95	PSA481-9i	-7, P, R, Y, G

¹ Surges up to 156 V for 2 s; see *Electrical Input Data*

² Efficiency at $V_{i\ nom}$ and $I_{o\ nom}$

³ Options iRY in a package

NFND: Not for new designs. Preferred for new designs

Note: The output voltage V_o is adjusted to 108% of $V_{o\ nom}$ for all models with option P or R, if they don't have option Y in addition.

Part Number Description

Positive switching regulator in case A01PSA or PSR

Nominal output voltage in Volt 5 to 48

Nominal output current in Ampere 1 to 5

Operational ambient temperature range T_A

-10 to 50 °C -2

-25 to 50 °C (customer-specific models) -5

-25 to 71 °C (option) -7

-40 to 71 °C -9

other (customer-specific models) 0

Inhibit input (standard for all -7 and -9 models) i

Control input for output voltage adjustment¹ R

Potentiometer¹ (option, NFND) P

RoHS-compliant for all 6 substances G

¹ Feature R excludes option P and vice versa.

Note: The sequence of options must follow the order above. Preferred for new designs.

Example: PSA121.5-9iRG designates a positive switching regulator with a 12 V, 1.5 A output, ambient temperature -40 to 71 °C, inhibit input, output adjust by R-input, RoHS-compliant for all 6 substances.

PSA 12 1.5 -9 i R G

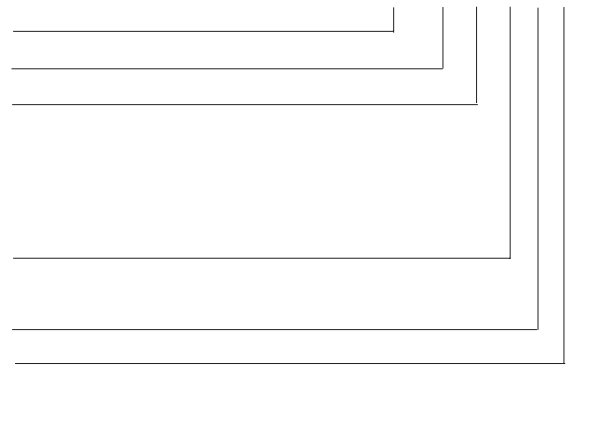

Customer-specific Models

Positive switching regulator in case A01	PSA
Nominal output voltage in Volt (without decimals)	12
Decimal places:	
0.0 V	Z
0.1 V	A
0.15 V	B
0.2 V	C
0.25 V	D
0.3 V	E
0.4 V	F
0.5 V	G
0.6 V	H
0.7 V	J
0.8 V	K
0.9 V	L
other	Y
Output current in Ampère	3
Identification character	A, B, ..
Temperature range and options	-9iRG

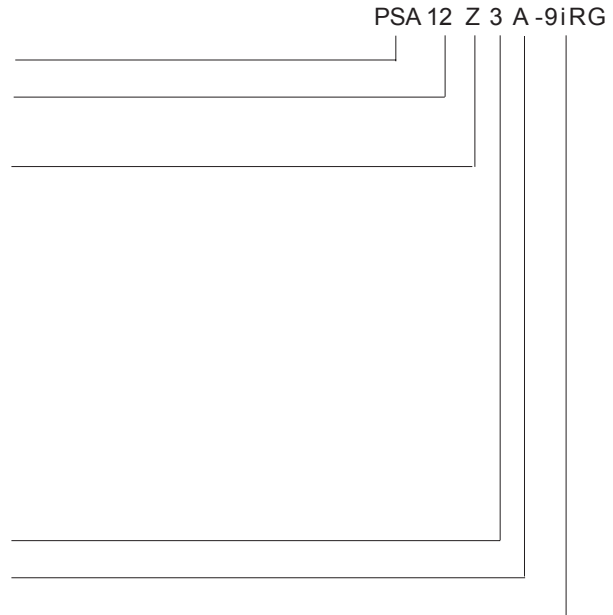

Produkt Marking

Type designation, applicable safety approval marks, pin allocation, patent information, company logo.
Label with input voltage range, nominal output voltage and

current, protection degree, batch no., serial no., data code comprising production site, version (modification status), date of production.

Functional Description

The switching regulators use the buck converter topology. The input is not electrically isolated from the output. During the on period of the switching transistor, current is transferred to the output, and energy is stored in the output choke. During the off period, this energy forces the current to continue flowing through the output, to the load, and back through the freewheeling diode. Regulation is ac-

complished by varying the duty cycle (on/off ratio) of the main switch. The regulator starts operating only when the input voltage exceeds the trigger level of the UVL (undervoltage lockout).

These regulators are ideal for a wide range of applications, where input to output isolation is not necessary or is already provided by an external front end (e.g., a transformer with rectifier). To optimize customer's needs, additional options and accessories are available.

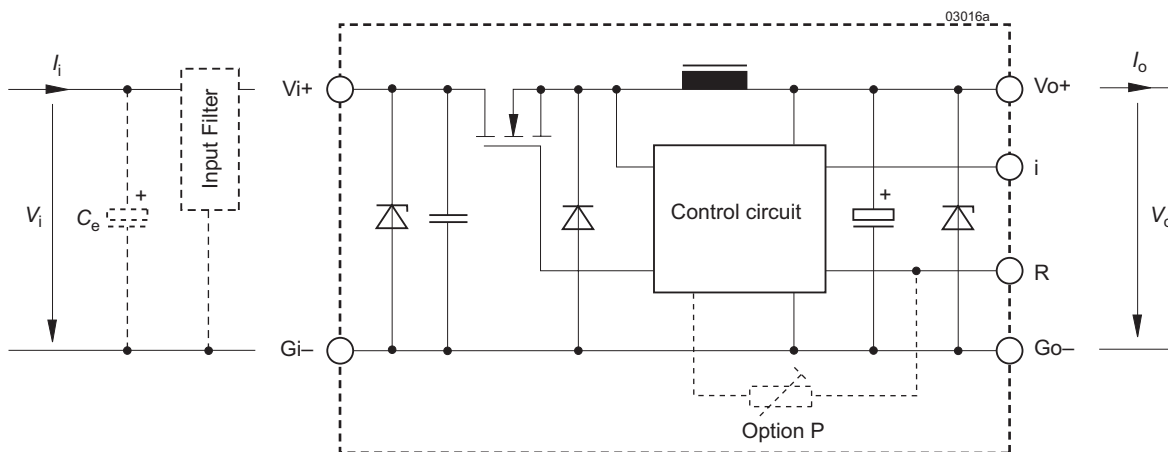

Fig. 1
Block diagram

Electrical Input Data

General Conditions: $T_A = 25^\circ\text{C}$, unless T_C is specified

Table 2a: Input data

Model			PSA55			PSA5A5			PSR54			PSA5A2			Unit
Characteristics		Conditions	min	typ	max	min	typ	max	min	typ	max	min	typ	max	
V_i	Operating input voltage	$I_o = 0 - I_{o\text{ nom}}$ $T_{C\text{ min}} - T_{C\text{ max}}$	7	35		7	35		7	40		8	40	V	
$\Delta V_{i\text{ o min}}$	Min. diff. voltage $V_i - V_o$			2			1.9			2			2.9		
$V_{i\text{ UVL}}$	Undervoltage lockout			6.3	6.6		6.3	6.4		6.3	6.5		7.3		7.6
$I_{i\text{ o}}$	No load input current	$I_o = 0, V_{i\text{ min}} - V_{i\text{ max}}$		45			50			45			50	mA	
$I_{i\text{ nr p}}$	Peak value of inrush current	$V_{i\text{ nom}}$		75			75			75			75	A	
$t_{i\text{ nr r}}$	Rise time of inrush current			2.5			2.5			2.5			2.5	μs	
$t_{i\text{ nr h}}$	Time to half-value			15			15			15			15		
$V_{i\text{ RFI}}$	EN 55011, 0.15 – 30 MHz	$V_{i\text{ nom}}, I_{o\text{ nom}}$	B ¹			--			B ¹			--			Class

Tab. 2b: Input data

Model			PSA123			PSA153			PSA242.5			Unit	
Characteristics		Conditions	min	typ	max	min	typ	max	min	typ	max		
V_i	Operating input voltage	$I_o = 0 - I_{o\text{ nom}}$ $T_{C\text{ min}} - T_{C\text{ max}}$	15		40	19		40	29		60	V	
$\Delta V_{i\text{ o min}}$	Min. diff. voltage ($V_i - V_o$)				3			4					5
$V_{i\text{ UVL}}$	Undervoltage lockout			7.3	8.0		7.3	9.0		12	13.7		
$I_{i\text{ o}}$	No load input current	$I_o = 0, V_{i\text{ min}} - V_{i\text{ max}}$			50			50			50	mA	
$I_{i\text{ nr p}}$	Peak value of inrush current	$V_{i\text{ nom}}$		75			150			150		A	
$t_{i\text{ nr r}}$	Rise time of inrush current			2.5			2.5			2.5		μs	
$t_{i\text{ nr h}}$	Time to half-value			15			15			15			
$V_{i\text{ RFI}}$	EN 55011 0.15 – 30 MHz	$V_{i\text{ nom}}, I_{o\text{ nom}}$	--			--			--			Class	

Tab. 2c: Input data

Model			PSR52			PSR53			PSR122.5			Unit	
Characteristics		Conditions	min	typ	max	min	typ	max	min	typ	max		
V_i	Operating input voltage	$I_o = 0 - I_{o\text{ nom}}$ $T_{C\text{ min}} - T_{C\text{ max}}$	8		80	8		80	15		80	V	
$\Delta V_{i\text{ o min}}$	Min. diff. voltage ($V_i - V_o$)				3			3					3
$V_{i\text{ UVL}}$	Undervoltage lockout			7.3	7.6		7.3	7.6		7.3	8		
$I_{i\text{ o}}$	No load input current	$I_o = 0, V_{i\text{ min}} - V_{i\text{ max}}$			40			40			35	mA	
$I_{i\text{ nr p}}$	Peak value of inrush current	$V_{i\text{ nom}}$		150			150			150		A	
$t_{i\text{ nr r}}$	Rise time of inrush current			2.5			2.5			2.5		μs	
$t_{i\text{ nr h}}$	Time to half-value			15			15			15			
$V_{i\text{ RFI}}$	EN 55011 0.15 – 30 MHz	$V_{i\text{ nom}}, I_{o\text{ nom}}$	B ²			B ²			B ²			Class	

¹ With $C_i = 470\ \mu\text{F}/40\ \text{V}$ and input filter FP38; see *Accessories*.

² With $C_i = 470\ \mu\text{F}/100\ \text{V}$ and input filter FP80; see *Accessories*.

Table 2d: Input data. General Conditions as per table 2a

Model			PSR152.5			PSR242			PSR362			PSA121.5			Unit
Characteristics		Conditions	min	typ	max	min	typ	max	min	typ	max	min	typ	max	
V_i	Operating input voltage	$I_o = 0 - I_{o\ nom}$	19		80	29		80	42		80	18		144 ¹	V
$\Delta V_{i0\ min}$	Min. diff. voltage $V_i - V_o$	$T_{C\ min} - T_{C\ max}$			3			4			5			6	
$V_{i\ UVL}$	Undervoltage lockout		7.3		9.0	12		13.7	19		20.5	12		12.5	
I_{i0}	No load input current	$I_o = 0, V_{i\ min} - V_{i\ max}$			35			35			40			20	mA
$I_{inr\ p}$	Peak value of inrush current	$V_{i\ nom}$			150			150			150			150	A
$t_{inr\ r}$	Rise time of inrush current				2.5			2.5			2.5			2.5	μ s
$t_{inr\ h}$	Time to half-value				15			15			15			15	
$V_{i\ RFI}$	EN 55011, 0.15 – 30 MHz	$V_{i\ nom}, I_{o\ nom}$			B ²			B ²			B ²			B ³	Class

Table 2e: Input data. General Conditions as per table 2a

Model			PSA151.5			PSA241.5			PSA361			PSA481			Unit
Characteristics		Conditions	min	typ	max	min	typ	max	min	typ	max	min	typ	max	
V_i	Operating input voltage	$I_o = 0 - I_{o\ nom}$	22		144 ¹	31		144 ¹	44		144 ¹	58		144 ¹	V
$\Delta V_{i0\ min}$	Min. diff. voltage $V_i - V_o$	$T_{C\ min} - T_{C\ max}$			7			7			8			10	
$V_{i\ UVL}$	Undervoltage lockout		18		18.5	22		23	31		32	44		45	
I_{i0}	No load input current	$I_o = 0, V_{i\ min} - V_{i\ max}$			20			20			25			25	mA
$I_{inr\ p}$	Peak value of inrush current	$V_{i\ nom}$			150			150			150			150	A
$t_{inr\ r}$	Rise time of inrush current				2.5			2.5			2.5			2.5	μ s
$t_{inr\ h}$	Time to half-value				15			15			15			15	
$V_{i\ RFI}$	EN 55011, 0.15 – 30 MHz	$V_{i\ nom}, I_{o\ nom}$			B ³			B ³			B ³			B ³	Class

¹ Surges up to 156 V for 2 s

² With $C_i = 470\ \mu$ F / 100 V and input filter FP80; see *Accessories*

³ With $C_i = 2 \times 3.3\ \mu$ F / 250 V MKT and input filter FP144; see *Accessories*

External Input Circuitry

The sum of the lengths of the supply lines to the source or to the nearest capacitor $\geq 100\ \mu$ F ($a + b$) should not exceed 5 m, unless option L is fitted. This option is recommended in order to prevent power line oscillations and reduce superimposed interference voltages.

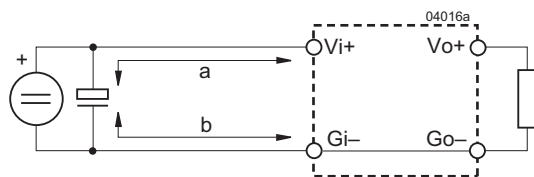

Fig. 2
 Switching regulator with long supply lines.

Electrical Output Data

General conditions:

- $T_A = 25\text{ °C}$, unless T_C is specified
- R-input open (or V_o set to $V_{o\text{ nom}}$ with option P)

Table 3a: Output data

Model			PSA55		PSA5A5		PSR54		PSA5A2		Unit	
Characteristics		Conditions	min	typ	max	min	typ	max	min	typ	max	
V_o	Output voltage ¹	$V_{i\text{ nom}}, I_{o\text{ nom}}$	4.97	5.03	5.05	5.15	4.97	5.03	5.05	5.15	V	
I_o	Output current	$V_{i\text{ min}} - V_{i\text{ max}}$	0	5.0	0	5.0	0	4.0	0	2.0	A	
I_{oL}	Output current limitation	$T_{C\text{ min}} - T_{C\text{ max}}$	5.0	6.5	5.0	6.5	4.0	5.2	2.0	2.6		
v_o	Output voltage noise	Switching frequ.	$V_{i\text{ nom}}, I_{o\text{ nom}}$		70		15 40		40		mV _{pp}	
		Total	IEC/EN 61204 BW = 20 MHz		24 70		100		19 60			
ΔV_{oV}	Static line regulation	$V_{i\text{ min}} - V_{i\text{ max}}, I_{o\text{ nom}}$	30	40		40	30	40		40	mV	
ΔV_{oI}	Static load regulation	$V_{i\text{ nom}}, I_o = 0 - I_{o\text{ nom}}$	20	25		25	10	45		20		
v_{od}	Dynamic voltage regulation	Voltage deviation	$V_{i\text{ nom}}$		250		300		200		300	
t_d		Recovery time	$I_{o\text{ nom}} \leftrightarrow \frac{1}{3} I_{o\text{ nom}}$		40		100		40		100	μs
α_{Vo}	Temperature coefficient $\Delta V_o / \Delta T_C (T_{C\text{ min}} - T_{C\text{ max}})$	$V_{i\text{ min}} - V_{i\text{ max}}$ $I_o = 0 - I_{o\text{ nom}}$		± 0.02		± 0.02		± 0.02		± 0.02	%/K	

Table 3b: Output data

Model			PSA123			PSA153			PSA242.5			Unit
Characteristics		Conditions	min	typ	max	min	typ	max	min	typ	max	
V_o	Output voltage ¹	$V_{i\text{ nom}}, I_{o\text{ nom}}$	11.9	12.1	14.9	15.1	23.8	24.2			V	
I_o	Output current	$V_{i\text{ min}} - V_{i\text{ max}}$	0	3.0	0	3.0	0	2.5			A	
I_{oL}	Output current limitation	$T_{C\text{ min}} - T_{C\text{ max}}$	3.0	3.9	3.0	3.9	2.5	3.25				
v_o	Output voltage noise	Switching frequ.	$V_{i\text{ nom}}, I_{o\text{ nom}}$		90		110		150		mV _{pp}	
		Total	IEC/EN 61204 BW = 20 MHz		110		150		170			
ΔV_{oV}	Static line regulation	$V_{i\text{ min}} - V_{i\text{ max}}, I_{o\text{ nom}}$		70		85		180			mV	
ΔV_{oI}	Static load regulation	$V_{i\text{ nom}}, I_o = 0 - I_{o\text{ nom}}$		40		60		140				
v_{od}	Dynamic load regulation	Voltage deviat.	$V_{i\text{ nom}}$		360		450		720			
t_d		Recovery time	$I_{o\text{ nom}} \leftrightarrow \frac{1}{3} I_{o\text{ nom}}$		120		120		160		μs	
α_{Vo}	Temperature coefficient $\Delta V_o / \Delta T_C (T_{C\text{ min}} - T_{C\text{ max}})$	$V_{i\text{ min}} - V_{i\text{ max}}$ $I_o = 0 - I_{o\text{ nom}}$		± 0.02		± 0.02		± 0.02		± 0.02	%/K	

¹ Models with option R, but without option Y, are adjusted to 108% of $V_{o\text{ nom}}$. Models with option P are preadjusted to 108% of $V_{o\text{ nom}}$.

Table 3c: Output data. General conditions as per table 3a

Model			PSR52			PSR53			PSR122.5			Unit			
Characteristics			Conditions			min	typ	max	min	typ	max	min	typ	max	
V_o	Output voltage ¹		$V_{i\text{ nom}}, I_{o\text{ nom}}$			4.97		5.03	4.97		5.03	11.9		12.1	V
I_o	Output current		$V_{i\text{ min}} - V_{i\text{ max}}$			0		2.0	0		3.0	0		2.5	A
I_{oL}	Output current limitation		$T_{C\text{ min}} - T_{C\text{ max}}$			2.0		2.6	3.0		3.9	2.5		3.25	
v_o	Output voltage noise	Switching frequ.	$V_{i\text{ nom}}, I_{o\text{ nom}}$			20	40		20	60		30	70		mV _{pp}
		Total	IEC/EN 61204 BW = 20 MHz			24	60		24	80		35	90		
ΔV_{oV}	Static line regulation		$V_{i\text{ min}} - V_{i\text{ max}}, I_{o\text{ nom}}$			30	40		30	45		30	45		mV
ΔV_{oI}	Static load regulation		$V_{i\text{ nom}}, I_o = 0 - I_{o\text{ nom}}$			20	25		20	25			40		
v_{od}	Dynamic load regulation	Voltage deviat.	$V_{i\text{ nom}}$			100			100			180			μs
t_d		Recovery time	$I_{o\text{ nom}} \leftrightarrow \frac{1}{3} I_{o\text{ nom}}$ IEC/EN 61204			50			50			60			
α_{Vo}	Temperature coefficient $\Delta V_o / \Delta T_C (T_{C\text{ min}} - T_{C\text{ max}})$		$V_{i\text{ min}} - V_{i\text{ max}}$ $I_o = 0 - I_{o\text{ nom}}$					±0.02			±0.02			±0.02	%/K

Table 3d: Output data. General conditions as per table 3a

Model			PSR152.5			PSR242			PSR362			PSA121.5			Unit			
Characteristics			Conditions			min	typ	max	min	typ	max	min	typ	max	min	typ	max	
V_o	Output voltage ¹		$V_{i\text{ nom}}, I_{o\text{ nom}}$			14.91	15.09		23.86	24.14		35.78	36.22		11.93	12.07		V
I_o	Output current		$V_{i\text{ min}} - V_{i\text{ max}}$			0	2.5		0	2.0		0	2.0		0	1.5		A
I_{oL}	Output current limitation		$T_{C\text{ min}} - T_{C\text{ max}}$			2.5	3.25		2.0	2.6		2.0	2.6		1.5	1.9		
v_o	Output voltage noise	Switching frequ.	$V_{i\text{ nom}}, I_{o\text{ nom}}$			40	110		30	150		80	200		20	40		mV _{pp}
		Total	IEC/EN 61204 BW = 20 MHz			50	150		40	170		85	220		24	50		
ΔV_{oV}	Static line regulation		$V_{i\text{ min}} - V_{i\text{ max}}, I_{o\text{ nom}}$			70	85		60	220		200	250		20	80		mV
ΔV_{oI}	Static load regulation		$V_{i\text{ nom}}, I_o = 0 - I_{o\text{ nom}}$			40	50		90	160		125	160		20	30		
v_{od}	Dynamic voltage regulation	Voltage deviation	$V_{i\text{ nom}}$			180			210			250			50			μs
t_d		Recovery time	$I_{o\text{ nom}} \leftrightarrow \frac{1}{3} I_{o\text{ nom}}$ IEC/EN 61204			60			80			100			50			
α_{Vo}	Temperature coefficient $\Delta V_o / \Delta T_C (T_{C\text{ min}} - T_{C\text{ max}})$		$V_{i\text{ min}} - V_{i\text{ max}}$ $I_o = 0 - I_{o\text{ nom}}$					±0.02			±0.02			±0.02			±0.02	%/K

Table 3e: Output data. General conditions as per table 3a

Model			PSA151.5			PSA241.5			PSA361			PSA481			Unit			
Characteristics			Conditions			min	typ	max	min	typ	max	min	typ	max	min	typ	max	
V_o	Output voltage ¹		$V_{i\text{ nom}}, I_{o\text{ nom}}$			14.91	15.09		23.86	24.14		35.78	36.22		47.71	48.29		V
I_o	Output current		$V_{i\text{ min}} - V_{i\text{ max}}$			0	1.5		0	1.5		0	1.2		0	1.0		A
I_{oL}	Output current limitation		$T_{C\text{ min}} - T_{C\text{ max}}$			1.5	1.9		1.5	1.9		1.2	1.5		1.0	1.3		
v_o	Output voltage noise	Switching frequ.	$V_{i\text{ nom}}, I_{o\text{ nom}}$			25	50		45	75		45	80		50	75		mV _{pp}
		Total	IEC/EN 61204 BW = 20 MHz			29	60		50	120		50	120		55	120		
ΔV_{oV}	Static line regulation		$V_{i\text{ min}} - V_{i\text{ max}}, I_{o\text{ nom}}$			40	40		40	80		80	120		90	120		mV
ΔV_{oI}	Static load regulation		$V_{i\text{ nom}}, I_o = 0 - I_{o\text{ nom}}$			20	50		30	40		40	80		60	100		
v_{od}	Dynamic voltage regulation	Voltage deviation	$V_{i\text{ nom}}$			50			50			200			300			μs
t_d		Recovery time	$I_{o\text{ nom}} \leftrightarrow \frac{1}{3} I_{o\text{ nom}}$ IEC/EN 61204			50			60			40			100			
α_{Vo}	Temperature coefficient $\Delta V_o / \Delta T_C (T_{C\text{ min}} - T_{C\text{ max}})$		$V_{i\text{ min}} - V_{i\text{ max}}$ $I_o = 0 - I_{o\text{ nom}}$					±0.02			±0.02			±0.02			±0.02	%/K

¹ Models with option R, but without option Y, are adjusted to 108% of $V_{o\text{ nom}}$. Models with option P are preadjusted to 108% of $V_{o\text{ nom}}$.

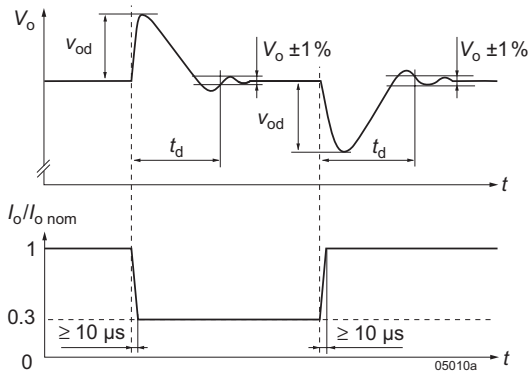

Fig. 3s
Switching regulator with long supply lines.

Thermal Considerations

When a switching regulator is located in free, quasi-stationary air (convection cooling) at a temperature $T_A = 71\text{ }^\circ\text{C}$ and is operated at $I_o \text{ nom}$, the case temperature T_C will be about $95\text{ }^\circ\text{C}$ after the warm-up phase, measured at the

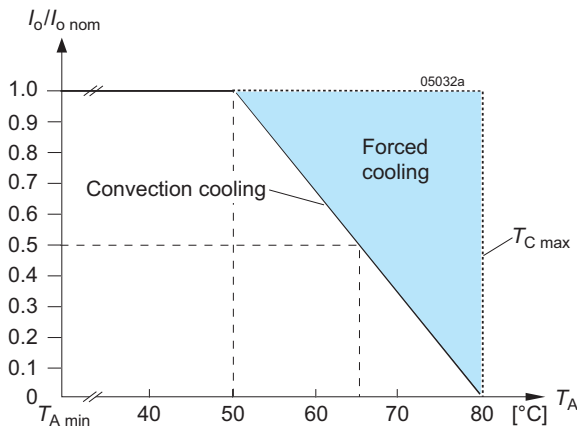

Fig. 4a
Output current versus temperature (models -2)

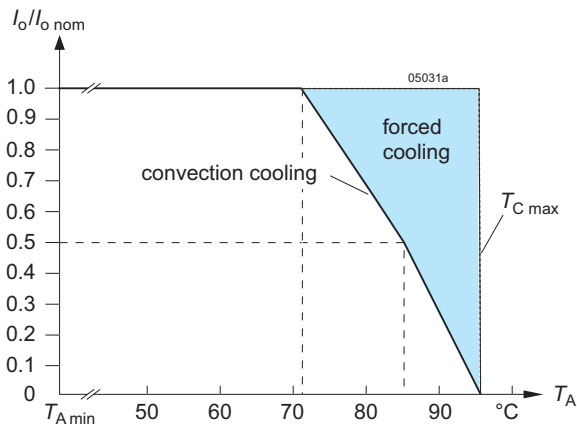

Fig. 4b
Output current versus temperature (models -7 and -9)

measuring point of case temperature T_C ; see *Mechanical Data*.

Under practical operating conditions, T_A may exceed $71\text{ }^\circ\text{C}$, provided that additional measures (heat sink, fan etc.) are taken to ensure that T_C does not exceed $T_{C \text{ max}}$.

Output protection and Short Circuit Behavior

A voltage suppressor diode, which in worst case conditions fails into a short circuit protects the output against an internally generated overvoltage. Such an overvoltage could occur due to a failure of either the control circuit or the switching transistor. The output protection is not designed to withstand externally applied overvoltages.

A constant current limitation circuit holds the output current almost constant, when an overload or a short circuit is applied to the output. It acts self-protecting and recovers automatically after removal of the overload or short-circuit condition.

Parallel and Series Connection

Outputs of equal nominal voltages can be parallel-connected. However, the use of a single regulator with higher output power, is always the better solution.

In parallel-connected operation, one or several outputs may operate continuously at their current limit knee-point which will cause an increase of the heat generation. Consequently, the max. ambient temperature should be reduced by 10 K.

Outputs can be series-connected with any other regulator. In series-connection the maximum output current is limited by the lowest current limitation, but electrically separated source voltages are needed for each regulator.

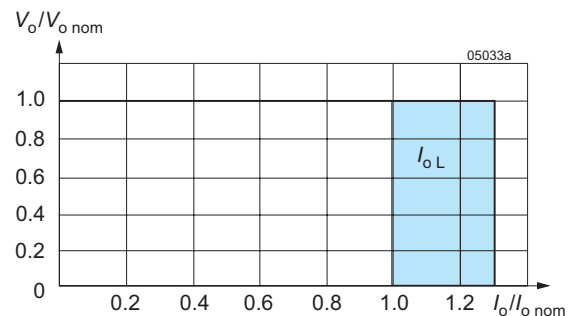

Fig. 5
Overload and short-circuit behavior V_o versus I_o

Auxiliary Functions

i Inhibit (Remote On / Off)

The inhibit input allows the switching regulator output to be disabled via a control signal. In systems with several

converters, this feature can be used, for example, to control the activation sequence of the converters by a logic signal (TTL, CMOS, etc.). No output voltage overshoot will occur at switch-on.

Note: With open i-pin, the output is enabled.

LED Output Voltage Indicator

A yellow LED indicator is illuminated, when the output voltage is present (not for -2 models).

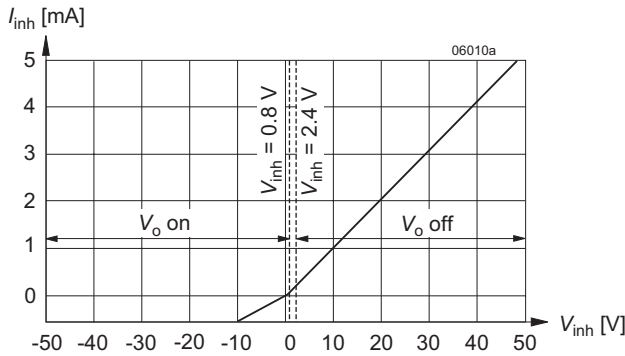

Fig. 6
 Typical inhibit current I_{inh} versus inhibit voltage V_{inh}

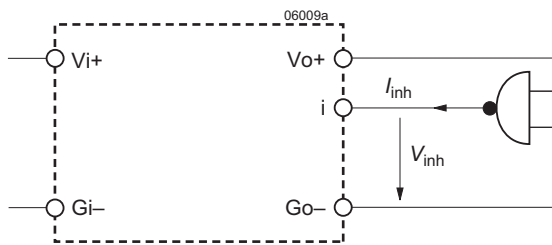

Fig. 7
 Definition of I_{inh} and V_{inh}

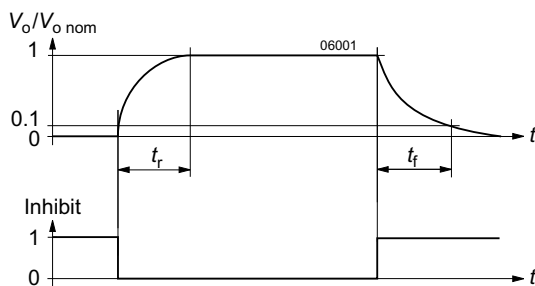

Fig. 8
 Output response as a function of inhibit signal

Table 4: Inhibit characteristics

Characteristics		Conditions	min	typ	max	Unit
V_{inh}	Inhibit input voltage	$V_o = \text{on}$	$V_{i \min} - V_{i \max}$	-10	+0.8	V
		$V_o = \text{off}$	$T_{C \min} - T_{C \max}$	+2.4	+50	
t_r	Switch-on time	$V_i = V_{i \text{ nom}}$		2	ms	
t_f	Switch-off time	$R_L = V_{o \text{ nom}} / I_{o \text{ nom}}$		4		
$I_{i \text{ inh}}$	Input current when inhibited	$V_i = V_{i \text{ nom}}$		10	mA	

Electromagnetic Compatibility (EMC)

Electromagnetic Immunity

General condition: Case not earthed.

Table 5: Immunity type tests

Phenomenon	Standard	Class Level	Coupling mode ¹	Value applied	Waveform	Source Imped.	Test procedure	In oper.	Perf. crit. ²
Voltage surge ³	IEC 60571-1	3 ³	i/c, +i/-i	800 V _p	100 μs	100 Ω	1 pos. and 1 neg. surge per coupling mode	yes	B
				1500 V _p	50 μs				
				3000 V _p	5 μs				
				4000 V _p	1 μs				
				7000 V _p	100 ns				
Electrostatic discharge ⁵	IEC/EN 61000-4-2	3 ³ 2 ⁴	contact discharge to case	6000 V _p ³ 4000 V _p ⁴	1/50 ns	330 Ω	10 positive and 10 negative discharges	yes	B ⁵
Electromagnetic field	IEC/EN 61000-4-3	3 ³ 2 ⁴	antenna	10 V/m ³ 3 V/m ⁴	AM 80% 1 kHz		80 – 1000 MHz	yes	A
Electrical fast transients/burst ⁵	IEC/EN 61000-4-4	3 ³ 2 ⁴	i/c, +i/-i	2000 V _p 1000 V _p s	bursts of 5/50 ns 5 kHz rep. rate transients with 15 ms burst duration and a 300 ms period	50 Ω	60 s positive 60 s negative transients per coupling mode	yes	A ⁵
Surges ⁵	IEC/EN 61000-4-5	2 ³	i/c	1000 V _p	1.2/50 μs	12 Ω	5 pos. and 5 neg. surges per coupling mode	yes	B ⁵
		2	+i/-i	500 V _p		2 Ω			
Conducted disturbances	IEC/EN 61000-4-6	3 ³ 2 ⁴	i, o, signal wires	10 VAC ³ 3 VAC ⁴	AM 80% 1 kHz	150 Ω	0.15 – 80 MHz	yes	A

¹ i = input, o = output, c = case.

² A = Normal operation, no deviation from specifications, B = Normal operation, temporary loss of function or deviation from specs possible

³ Not applicable for -2 models

⁴ Valid for -2 models

⁵ With the filters and input caps as specified in the foot notes of table 2

Electromagnetic Emission

For emission levels refer to *Electrical Input Data*.

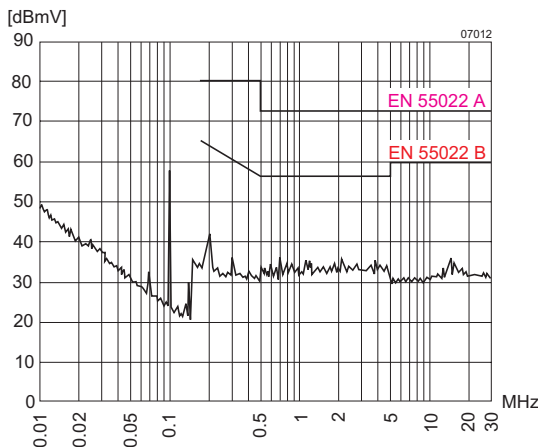

Fig. 8
 Typical disturbance voltage (quasi-peak) at the input according to EN 55011, measured at $V_{i,nom}$ and $I_{o,nom}$.

Immunity to Environmental Conditions

Table 6: Mechanical and climatic stress

Test	Method	Standard	Test Conditions	Status
Cab	Damp heat steady state	IEC/EN 60068-2-78 MIL-STD-810D section 507.2	Temperature: 40 ±2 °C Relative humidity: 93 ±2/-3 % Duration: 56 days	Regulator not operating
Ea	Shock (half-sinusoidal)	IEC/EN 60068-2-27 MIL-STD-810D section 516.3	Acceleration amplitude: 50 g _n = 490 m/s ² Bump duration: 11 ms Number of bumps: 18 (3 each direction)	Regulator operating
Eb	Bump (half-sinusoidal)	IEC/EN 60068-2-29 MIL-STD-810D section 516.3	Acceleration amplitude: 25 g _n = 245 m/s ² Bump duration: 11 ms Number of bumps: 6000 (1000 each direction)	Regulator operating
Fc	Vibration (sinusoidal)	IEC/EN 60068-2-6 MIL-STD-810D section 514.3	Acceleration amplitude: 0.35 mm (10 – 60 Hz) 5 g _n = 49 m/s ² (60 – 2000 Hz) Frequency (1 Oct/min): 10 – 2000 Hz Test duration: 7.5 h (2.5 h each axis)	Regulator operating
Fda	Random vibration wide band Reproducibility high	IEC/EN 60068-2-35 DIN 40046 part 23	Acceleration spectral density: 0.05 g ² /Hz Frequency band: 20 – 500 Hz Acceleration magnitude: 4.9 g _{n rms} Test duration: 3 h (1 h each axis)	Regulator operating
Kb	Salt mist, cyclic (sodium chloride NaCl solution)	IEC/EN 60068-2-52	Concentration: 5% (30 °C) Duration: 2 h per cycle Storage: 40 °C, 93% rel. humidity Storage duration: 22 h per cycle Number of cycles: 3	Regulator not operating

Temperatures

Table 7: Temperature specifications, valid for an air pressure of 800 - 1200 hPa (800 - 1200 mbar)

Temperature			-2		-7 (Option)		-9		Unit
Characteristics	Conditions		min	max	min	max	min	max	
T _A	Ambient temperature ¹	Regulator operating	-10	50	-25	71	-40	71	°C
T _C	Case temperature		-10	80	-25	95	-40	95	
T _S	Storage temperature ¹	Non operational	-25	100	-40	100	-55	100	

¹ See *Thermal Considerations*

Reliability

Table 8: Typical MTBF and device hours

MTBF	Ground Benign	Ground Fixed		Ground Mobile	Device Hours ¹
	T _C = 40 °C	T _C = 40 °C	T _C = 70 °C	T _C = 50 °C	
MTBF accord. to MIL-HDBK-217F	789 000 h	200 000 h	104 000 h	104 000 h	5 100 000 h

¹ Statistical values, based on an average of 4300 working hours per year and in general field use



Mechanical Data

Dimensions in mm.

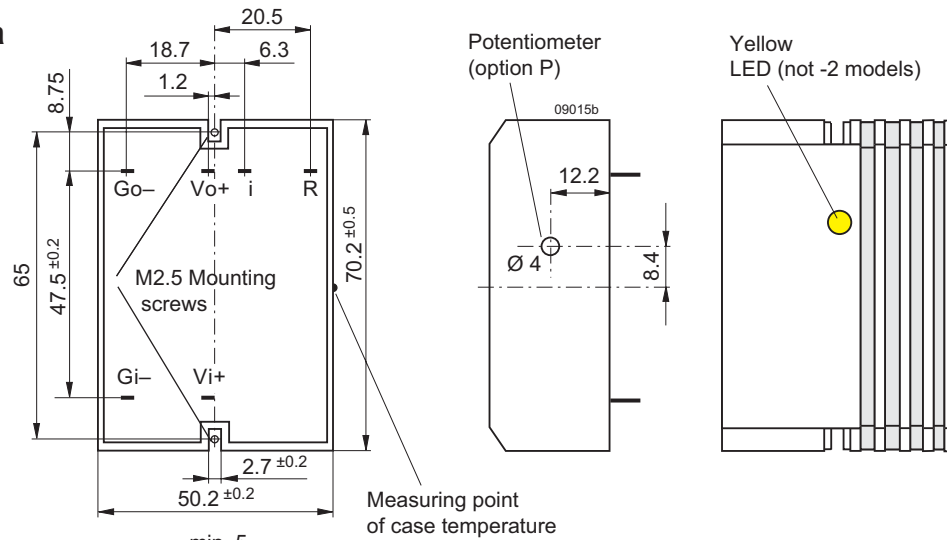

Fig. 9
Case A01,
weight 100 g,
Aluminum,
black anodized
and self cooling

Notes:

Pin i and pin R are only fitted if the regulator exhibits these options.

To avoid short circuits with the board, you can use the isolation pad HZZ01203-G; see Accessories.

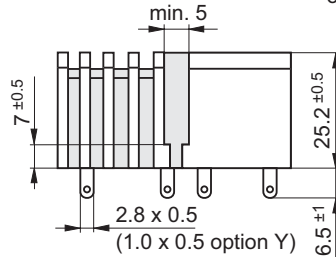
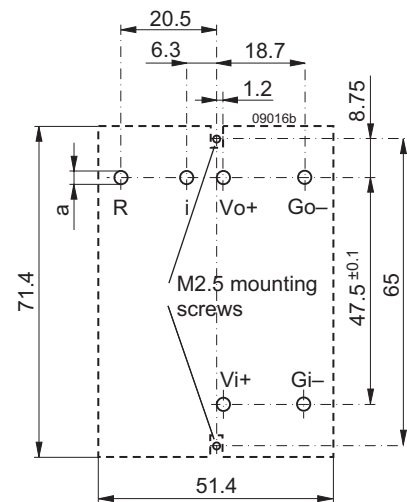

Fig. 10
Footprint.
a = rectangular slots 3.0 mm × 0.7 mm (or Ø 3.0 mm through-plated holes)
For option Y preview through-plated holes with Ø 1.3 to 1.5 mm for the pins and holes for two M 2.5 fastening screws.



Safety and Installation Instructions

Installation Instruction

Installation must strictly follow the national safety regulations in compliance with the enclosure, mounting, creepage, clearance, casualty, markings and segregation requirements of the end-use application.

Check for hazardous voltages before connecting.

The input and the output circuit are not separated, i.e. the negative path is internally interconnected.

Do not open the regulator !

Ensure that a regulator failure (e.g. by an internal short-circuit) does not result in a hazardous condition.

Cleaning Liquids

In order to avoid possible damage, any penetration of cleaning fluids must be prevented, since the power supplies are not hermetically sealed.

Protection Degree

The protection degree is IP 30 (IP 20, if equipped with option P). It applies only if the regulator is soldered to the mother board.

Standards and Approvals

All switching regulators have been approved according to IEC/EN 60950-1, and UL/CSA 60950-1 2nd Ed.

The regulators have been evaluated for:

- Building in
- The use in a pollution degree 2 environment
- Connecting the input to a secondary circuit, which is subject to a maximum transient rating of 1500 V.

The switching regulators are subject to manufacturing surveillance in accordance with the above mentioned standards and with ISO 9001:2008.

Isolation

Electric strength test voltage between input connected with

output against case: 1500 VDC, ≥ 1 s (for some PSA/PSR models only with version V103 or higher).

These tests are performed in the factory as routine test in accordance with EN 50116 and EN 60950.

Railway Application

The regulators have been developed observing the railway standards EN 50155 and EN 50121. All boards are coated with a protective lacquer.

Description of Options

-9 Extended Temperature Range

This option defines an extended temperature range as specified in table 7.

R Control (Output Voltage Adjust)

Note: With open R input, $V_o \approx V_{o\text{ nom}}$.

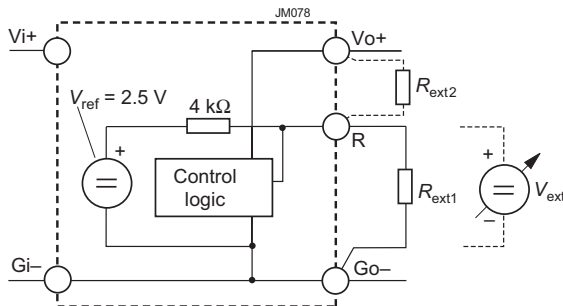

Fig. 11
Voltage adjustment via R-input

The output voltage V_o can either be adjusted with an external voltage source (V_{ext}) or with an external resistor (R_1 or R_2). The adjustment range is 0 – 108% of $V_{o\text{ nom}}$. The minimum differential voltage $\Delta V_{i0\text{ min}}$ between input and output (see *Electrical Input Data*) should be maintained.

a) $V_o = 0 - V_{o\text{ max}}$, using V_{ext} between pins R and Go-:

$$V_{\text{ext}} \approx 2.5 \text{ V} \cdot \frac{V_o}{V_{o\text{ nom}}} \quad V_o \approx V_{o\text{ nom}} \cdot \frac{V_{\text{ext}}}{2.5 \text{ V}}$$

Caution: To prevent damage, V_{ext} should not exceed 20 V, nor be negative.

b) $V_o = 0$ to $V_{o\text{ nom}}$, using $R_{\text{ext}1}$ between pins R and Go-:

$$R_{\text{ext}1} \approx \frac{4000 \Omega \cdot V_o}{V_{o\text{ nom}} - V_o} \quad V_o \approx \frac{V_{o\text{ nom}} \cdot R_{\text{ext}1}}{R_{\text{ext}1} + 4000 \Omega}$$

c) $V_o = V_{o\text{ nom}}$ to $V_{o\text{ max}}$, using $R_{\text{ext}2}$ between pins R and Go-:

$$R_{\text{ext}2} \approx \frac{4000 \Omega \cdot V_o \cdot (V_{o\text{ nom}} - 2.5 \text{ V})}{2.5 \text{ V} \cdot (V_o - V_{o\text{ nom}})}$$

$$V_o \approx \frac{V_{o\text{ nom}} \cdot 2.5 \text{ V} \cdot R_{\text{ext}2}}{2.5 \text{ V} \cdot (R_{\text{ext}2} + 4000 \Omega) - V_{o\text{ nom}} \cdot 4000 \Omega}$$

Caution: To prevent damage, $R_{\text{ext}2}$ should never be less than 47 kΩ.

Note: With option R, the output voltage V_o is adjusted to 108% of $V_{o\text{ nom}}$, if the regulator doesn't have option Y in addition.

P Potentiometer

Note: Option P is not recommended, if several regulators are operated in parallel connection.

Option P excludes R function; the R-input (pin 16) should be left open-circuit. The output voltage V_o can be adjusted in the range 90 – 108% of $V_{o\text{ nom}}$.

However, the minimum differential voltage $\Delta V_{i0\text{ min}}$ between input and output specified in *Electrical Input Data* should be observed.

Y Solder Pins

Models with rectangular pins 1.0 × 0.5 mm (length 6.5 mm). Such regulators can be fitted to PCB boards (through-plated holes with $\varnothing 1.3$ to 1.5 mm).

G RoHS Compliance

Models with G are RoHS-compliant for all six substances.

Accessories

A variety of electrical and mechanical accessories are available including:

- Filters and ring core chokes for ripple and interference reduction; see table 9.
- Tags and isolation pads for easy and safe PCB-mounting
- Adapters for chassis and DIN-rail mounting



Fig. 13
Different filters

Isolation Pads for PCB Mounting

In applications, where PCB mounting converters are placed on top of double sided boards, the use of an isolation pad is recommended. This fibre foil avoids short circuits and provide excellent protection against possible damage to tracks.

Part number: HZZ01203-G

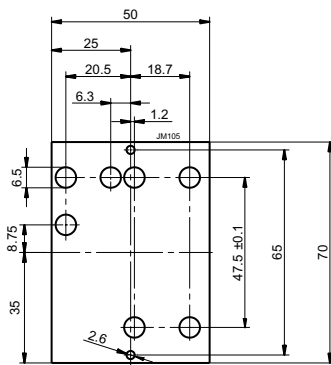

Fig. 12
Isolation pad HZZ01203-G
(ISOLATIONA,A01)
0.3 mm thick

Input filters

Different input filters are available; see table 9.

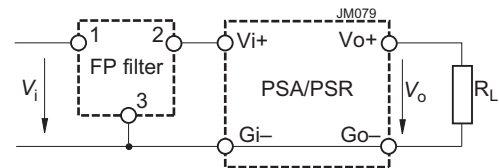

Fig. 14
Connection of the FP filter

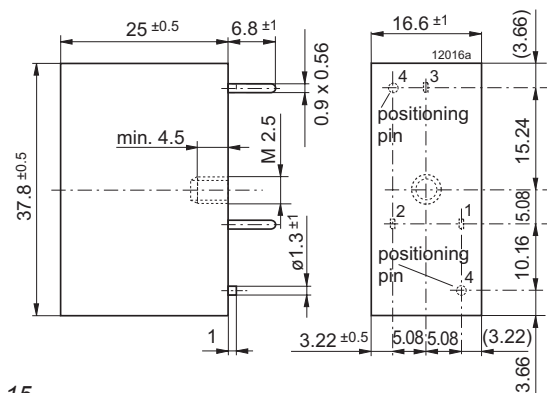

Fig. 15
Mechanical data of the FP filter.
Weight approx. 30 g

Table 9: Input filters FP. $T_A = 25^\circ\text{C}$ unless otherwise specified

Characteristics		Conditions	FP 38			FP 80			FP 144			Unit	
			min	typ	max	min	typ	max	min	typ	max		
I_{Fn}	Rated current	$L = 0.75 L_o$	4			4			2			A	
V_{Fn}	Rated voltage	$T_{C \min} - T_{C \max}$	5		40	5		80	15		144	VDC	
R_F	Ohmic resistance		18	20	22	18	20	22	90	95	100	mΩ	
L_o	No load inductance	$I_L = 0, T_{C \min} - T_{C \max}$	30	34	38	30	34	38	88	100	112	μH	
T_A	Ambient temperature	$I_F = I_{Fn}$	-40			80			-40			95	°C
T_C	Case temperature		-40			92			-40			98	
T_S	Storage temperature		-40			100			-40			100	

For currents $I_F > 4$ A the following derating takes place: $T_{A \max} = 100 - 1.3 \cdot I_F^2$ [°C], $T_{C \max} = 100 - 0.49 \cdot I_F^2$ [°C]

Mounting Supports

Different mounting supports for DIN-rail and chassis mounting are described in the Mounting Supports data sheet BCD.20007 posted on our web site. They also allow for fitting additional components



Fig. 16
Adapter for chassis mounting

For additional accessory product information, see the accessory data sheets listed with each product series at our web site.

NUCLEAR AND MEDICAL APPLICATIONS - These products are not designed or intended for use as critical components in life support systems, equipment used in hazardous environments, or nuclear control systems.

TECHNICAL REVISIONS - The appearance of products, including safety agency certifications pictured on labels, may change depending on the date manufactured. Specifications are subject to change without notice.

www.belpowersolutions.com/power