



FUH SERIES

Snap-in, For Through-Hole

- 105°C 2000 hours assured life.
- Directly mountable on printed circuit board without holders.
- Smaller low profile sizes than ordinary capacitors.
- Aluminum case designed explosion-proof vent.

Characteristics

Voltage Range	16 ~ 100V		160 ~ 450V					
Capacitance Range	470 ~ 47000uF		330 ~ 2200uF					
Temperature Range	-40 ~ +105°C		-25 ~ +105°C					
Capacitance Tolerance	+20% -20% (at 20°C, 120Hz)							
Leakage Current	$I = 3\sqrt{CV}$ uA max C: Capacitance, V:W.V. (After 5 minutes)							
Dissipation Factor (tan δ) (at 20°C, 120Hz)	Less than the value under table (%)							
	uF \ W.V.	10 ~ 16	25 ~ 35	50 ~ 63	80 ~ 100	160 ~ 250	350 ~ 450	
	47 ~ 390	-	-	-	15	15	20	
	470 ~ 3900	25	20	20	20	15	20	
	4700 ~ 8200	35	30	30	25			
	10000 ~ 22000	40	35	30				
27000 ~ 47000	45	40	35					
Stability at Low Temperature	Impedance ration at 120Hz between the -25°C or -40°C value and 20°C value shall not exceed :							
	Rated Voltage (V)	16	25	35~100	160~200	250~350	400	450
	Z-25°C/Z 20°C	5	4	4	4	4	8	8
	Z-40°C/Z 20°C	15	15	12	-	-	-	-
Load Life	The following specifications shall satisfied when the capacitors are restored to 20°C after rated working voltage applied for 2,000 hours at max. operating temperature with the rated ripple current.							
	Capacitance change	≤ ±20% of the initial value.						
	Dissipation factor	≤ ±200% of the initial specified value						
	Leakage current	≤ The initial specified value.						
Shelf Life	After storage for 1000 hours at 105°C with no voltage applied, the capacitor shall meet the specified limit in load life.							

Diagram of dimensions

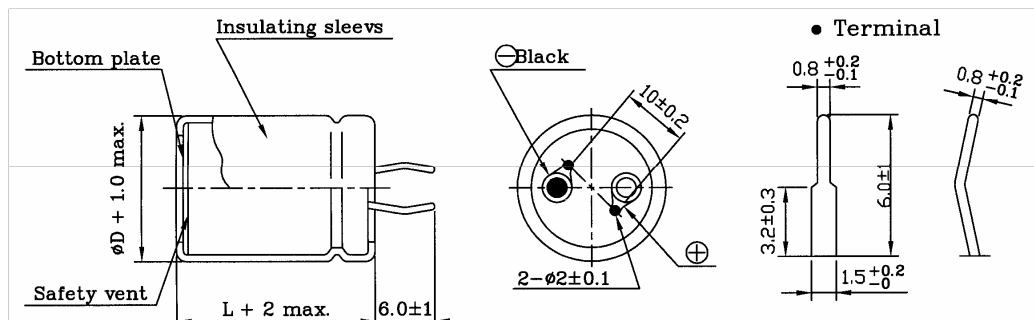

Multiplier for R.C. vs Temperature

Temp.(°C)	45	60	85	95	105
Multiplier	2.10	1.90	1.40	1.25	1.00

Multiplier for Ripple Current VS Frequency

Cap.(uF)\ (Hz)	60	120	1K	10K	50K - 100K
10 < Cap. ≤ 100	0.8	1	1.36	1.48	1.53
100 < Cap. ≤ 1000	0.8	1	1.25	1.35	1.38
1000 < Cap.	0.8	1	1.17	1.25	1.28



FUH SERIES

Snap-in, For Through-Hole

Standard Products Table

W.V(DC)	CAP. (μF)	Ripple Current A max. 105°C, 120Hz	Dimensions A		Dimensions B		Dimensions C	
			D φ	L	D φ	L	D φ	L
16	6800	2.02	22	30	-		-	
	10000	2.79	22	30	25	25	-	
	15000	3.24	22	50	25	40	30	35
	22000	4.08	25	45	30	40	-	
	33000	4.83	30	45	35	35	-	
	47000	6.32	35	45	-		-	
25	4700	1.92	22	25	-		-	
	6800	2.60	22	30	25	25	-	
	10000	3.50	22	40	25	35	30	30
	15000	4.58	25	45	30	35	-	
	22000	5.12	30	45	35	35	-	
	33000	6.09	35	50	-		-	
35	3300	1.84	22	25	-		-	
	4700	2.42	22	30	25	25	-	
	6800	3.24	22	40	25	35	30	30
	10000	3.96	25	45	30	35	-	
	15000	4.69	30	45	35	35	-	
	22000	5.50	35	50	-		-	
50	2200	1.65	22	30	25	25	-	
	3300	2.24	22	35	25	30	-	
	4700	2.95	22	45	25	40	30	30
	6800	3.26	25	50	30	40	-	
	10000	4.11	30	50	35	40	-	
	15000	5.05	35	50	-		-	
63	2200	1.65	22	35	25	30	-	
	3300	2.48	22	50	25	40	30	30
	4700	3.43	25	50	30	40	-	
	6800	4.64	30	50	35	40	-	
	10000	5.75	35	50	-		-	
80	1000	1.16	22	35	25	30	-	
	1500	1.74	22	40	25	35	30	30
	2200	2.25	22	50	25	45	30	35
	3300	3.30	30	50	35	40	-	
	4700	4.29	30	50	35	40	-	
	6800	5.66	35	50	-		-	
100	470	0.79	22	25	-		-	
	680	1.02	22	30	-		-	
	1000	1.38	22	35	25	30	-	
	1500	1.83	22	45	25	40	30	30
	2200	3.03	25	50	30	40	-	
	3300	4.59	30	50	35	40	-	
	4700	5.43	35	50	-		-	



FUH SERIES

Snap-in, For Through-Hole

Standard Products Table

W.V(DC)	CAP. (μF)	Ripple Current A max. 105°C, 120Hz	Dimensions A		Dimensions B		Dimensions C	
			D φ	L	D φ	L	D φ	L
160	330	0.98	22	25	-		-	
	470	1.21	22	35	25	25	-	
	680	1.64	22	45	25	40	-	
	1000	2.15	25	45	30	40	-	
	1500	2.80	30	50	35	40	-	
	2200	3.39	35	50	-		-	
200	220	0.92	22	25	-		-	
	330	1.21	22	35	25	30	-	
	470	1.62	22	40	25	30	-	
	680	2.04	25	40	30	35	-	
	1000	2.70	30	45	35	35	-	
	1500	3.43	35	50	-		-	
250	220	1.00	22	30	25	25	-	
	330	1.28	22	40	25	30	-	
	470	1.76	22	50	25	40	30	30
	680	2.22	25	50	30	40	35	35
	820	2.16	30	40	-		-	
	820	2.27	35	35	-		-	
	1000	2.80	35	40	-		-	
350	100	0.69	22	30	25	30	-	
	150	0.82	22	40	25	35	-	
	220	1.00	22	50	30	35	30	30
	330	1.35	30	40	35	35	-	
	470	1.70	35	40	-		-	
400	47	0.56	22	25	-		-	
	68	0.72	22	25	-		-	
	100	0.82	22	35	25	30	25	25
	150	0.98	22	45	25	40	25	30
	220	1.21	25	50	30	35	-	
	330	1.57	30	50	35	40	-	
	470	1.98	30	50	35	45	-	
450	47	0.60	22	25	-		-	
	68	0.80	22	35	25	30	-	
	100	0.90	22	40	25	30	-	
	150	1.05	22	50	25	40	30	30
	220	1.24	30	40	35	35	-	
	330	1.64	30	50	35	45	-	
	470	1.70	35	50	-		-	

ORDERING INFORMATION (CEL)



DAEWOO / PARTSNIC

Through-Hole Part Numbering System Example:

CEL = Leaded Type, **RM** = Leaded Radial 85°C Miniature Series, **102** = 1000µF, **M** =20% Tolerance, **1E** 25 Volts, **B** = Bulk,
1020 = Case size (Dia x H) = 10.0 x 20.0mm, **E** = 5.0mm

RM 102 M 1E B 1020 E

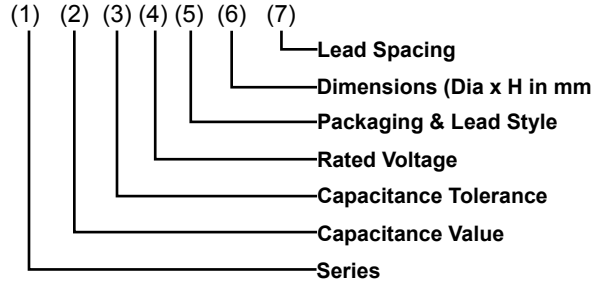

(1) Series

See Quick Guide on page 2
Example: RSS, RM, RMU,...

(2) Capacitance Value Code

Capacitance expressed in micro Farads (µF)
First two digits are significant figures
Third digit denotes the number of zeros
Use R for decimal point for values less than 10µF

Examples:

CODE	Capacitance
R10	0.1 µF
R68	0.68 µF
1R0	1.0 µF
100	10 µF
680	68 µF
471	470 µF
102	1000 µF
103	10000 µF

(3) Capacitance Tolerance Code

CODE	Cap. Tol.	CODE	Cap. Tol.
J	±5%	V	-10% ~ +20%
K	±10%	Q	-10% ~ +30%
M	±20%	T	-10% ~ +50%
R	+20%, -0%		

(4) Rated Voltage Code

CODE	Voltage	CODE	Voltage
0G	4.0V	2C	160V
0J	6.3V	2S	180V
1A	10V	2D	200V
1C	16V	2E	250V
1E	25V	2F	315V
1V	35V	2V	350V
1H	50V	2G	400V
1J	63V	2W	450V
1K	80V	3Z	1000V
2A	100V		

(5) Packaging Form & Lead Style Code (see page 7, 8, 9 for details)

	Code	Packaging Form & Lead Style
Bulk	B	Bulk: Standard Package
	L	"FL" Bulk: 4 -8ø Long Leads Formed to 5 mm Pitch
Snap-In	1	"SA/S1A": 10-13ø Snap-in Cut 5.0mm
	2	"SB/SB1": 16-13ø Snap-in Cut 5.0mm
	3	"SC/S2A": 10-13ø Snap-in Cut 4.5mm
	4	"SE/S2B": 16-18ø Snap-in Cut 4.5mm
	5	"SG/S3A": 4-8ø Snap-in Cut 7.5mm
Form	F	"FF/FCF": 4-8ø Forming Cut 6.5mm
Straight Cut	C	"CJ": 4-18ø Straight Cut 4.0mm
	6	"CR": 4-18ø Straight Cut 3.5mm
	7	"CS": 4-18ø Straight Cut 5.0mm
	8	"CE": 4-18ø Straight Cut 6.35mm
Ammo Tape (+) Leading	A	"TS"/"TSSA": 4-8ø Straight Ammo Detail Ranges: 4-6.3ø; F=2.5mm 8ø; F=3.5mm
		"T5/TAA": 4-8ø Form Tape & Ammo 5mm Pitch
		"T7/TSAA": 10ø Straight Ammo Tape 5mm Pitch
		"T9/TSAA": 13ø Straight Ammo Tape 5mm Pitch
		"TB/TSAA": 16-18ø Straight Ammo Tape 5mm Pitch
Tape & Reel (+) Leading	T	"TQ/TSSRA": 4-8ø Straight Ammo Detail Ranges: 4-6.3ø; F=2.5mm 8ø; F=3.5mm
		"T1/TRA": 4-13ø Form Tape & Reel 5mm Pitch
		"T3/TSRA": 10-13ø Straight Reel Tape 5mm Pitch

NOTE: Standard Pack Anode(+) Lead Leading FEEDS OFF FIRST
Special Option Cathode(-) Lead Leading available upon request
Standard Packages: B = Bulk, A = Ammo, T = Tape & Reel

(6) Dimension Code (Diameter x Height in mm)

Size Code	Diameter	Height	Size Code	Diameter	Height
0407	4	7	1835	18	35.5
0507	5	7	2240	22	40
0607	6.3	7	2545	25	45
0511	5	11	3035	30	35
0611	6.3	11	3500	35	100
0811	8	11	3501	35	110
1012	10	12.5	5102	51	120
1220	12.5	20	6303	63.5	130
1320	13	20	7604	76	140
1631	16	31.5	8904	89	140

(7) Lead Spacing Code (LS)

Code	X	A	B	C	D	E	J	F
LS	1.0	1.5	2.0	2.5	3.5	5.0	7.0	7.5
Code	K	M	G	P	H	Q	R	S
LS	8.0	10.0	10.5	12.0	12.5	12.8	15.0	16.0
Code	T	U	V	W	Y	Z		
LS	20.0	21.7	28.3	30.0	31.6	32		